

AIR DRIVEN GAS BOOSTER

MODEL 3G-SS-20

3G-SS-20

Hydraulics International, Inc. (HII) gas booster is designed to boost gas directly from a cascade system, a gas generation system, a cryogenic system or a high pressure compressor to outlet pressures of 3450-psi (238-bar). The unit ensures full fills even if the supply storage pressure drops as low as 300-psi (20 bar). The unit may be Driven manually, by means of its integral hand pump assembly (optional); a low pressure conventional air compressor; or Regulated high-Pressure air storage supply (SCUBA, SCBA or NITROGEN bottles).
Maximum 150psi (10 bar) air supply.

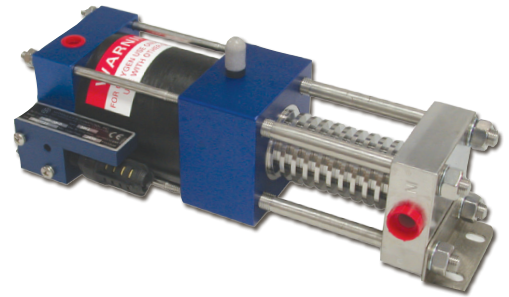

The high-pressure sections of the booster are cooled by the drive exhaust air and operate dry, non-lubricated. In the shop air drive mode, non-contaminated outlet gas is assured because of complete dual vented separation from the drive section.

IDEAL FOR GENERAL AVIATION, MUNICIPAL FIRE, RESCUE, RECREATIONAL & TECHNICAL DIVERS, DIVE SHOPS, YACHTS AND RESCUE SERVICES

KEY BENEFITS:

- **Increase System Capacity:** Up to 50% more fills
- **Eliminate Cascading:** Allows you to fill or top-off from storage as low as 300 psi (20 bar)

KEY FEATURES:

- **Boost** gas pressure from 300 psi to 3450 psi
- **Hold Pressure.** Can be controlled to stop at any predetermined pressure and hold that pressure indefinitely without consuming power, and restart under full load
- **Intrinsically Safe.** Compressed air reduces risk of heat, flame, spark, or electrical shock
- **Contamination FREE.** Separation between drive and gas section uses three static seals with dual vents

OPTIONAL CONTROLS:

- **Manually Driven with Integral Hand Pump Assembly**
2000 psi (138 bar) MAX. outlet pressure
- **High Pressure Air Controls**
(HP regulator, relief valve and on/off valve)
- **Oxygen Fill Accessory Kit**
(inlet CGA connector, 60" inlet & outlet hoses, outlet filter, outlet on/off valve, gauge, and DIN connector with bleeder)
- **Watertight Protective Case with Wheels**
22"L x 14"W x 9"H (559 mm x 356 mm x 229 mm)
- **Safety Low & High Pressure Cutoff Valves**
(set to automatically stop & restart the booster)
- **Outlet Pressure Relief Valve**

PERFORMANCE:

Approximate fill-time* for a 19 cu-ft (0.54 cu- m³) O₂ Bottle to 2,400-psi (165 bar)

SYSTEM PRESSURE AFTER EQUALIZATION	APPROX. FILL-TIME	APPROX. FILL RATES
2000 psi (138 bar)	1.0 minutes	3.0 scfm (85 nl/min)
1500 psi (103 bar)	3.1 minutes	2.3 scfm (65 nl/min)
1000 psi (69 bar)	7.3 minutes	1.5 scfm (42 nl/min)
500 psi (34 bar)	20 minutes	0.8 scfm (23 nl/min)

*Based on 105-psi shop air and 60 cycles per minute. NOTE: DO NOT exceed 200 psi/min. transfer rate for pure oxygen and 50-70 psi/min. during mixing.

PETRICHOR GLOBAL Pte. Ltd.

AIR DRIVEN GAS BOOSTER MODEL 3G-SS-20

SPECIFICATIONS:

▪ Dimensions:	12.05" L x 4.9" D x 3.4" H	▪ Air Drive:	1/4" NPTF
▪ Weight:	11.6-pounds (5.2 Kg)	▪ Gas Inlet:	3/8" Female JIC. (9/16" x 18 straight threads)
▪ Pressure Ratio:	23:1	▪ Gas Outlet:	3/8" Female JIC. (9/16" x 18 straight threads)
▪ Maximum Outlet Pressure:	3,450-psi (238 Bar)	▪ Exhaust:	1/4" NPTF
▪ Max/Min Drive Air Pressure:	150/12-psi (10/0.8 Bar)	▪ Remote Pilot:	1/8" NPTF

PERFORMANCE CURVE

(Assume an air drive source of approximately 100 psi from 1/4" I.D. piping)

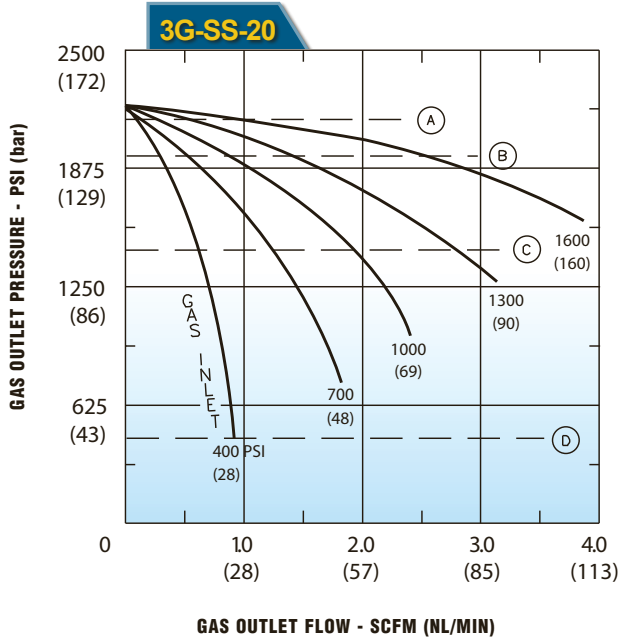

DIMENSIONAL DATA

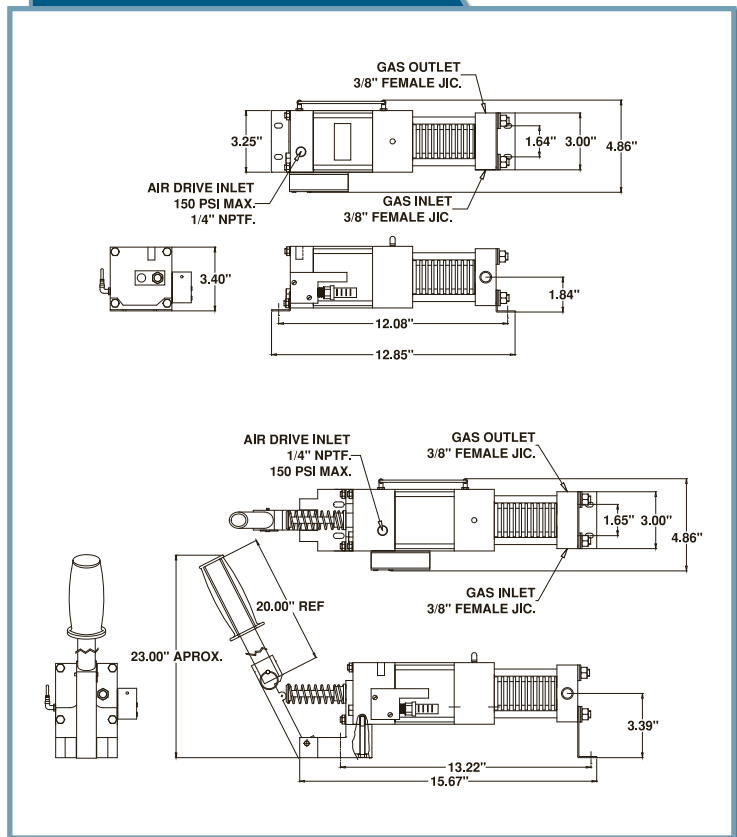

Other HII Quality Products: 100% USA Made



Booster mounted on a Watertight Protective Case



Electric Driven Booster Packages

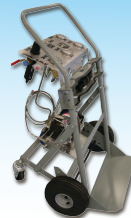

2-Bottle Hand Truck with Booster



Portable Booster System with Safety Valves